

ON-SITE GUARDRAIL GARDEN TRAINING

MATT™ (Median Attenuating TREND® Terminal) End Treatment Component Checklist

Date Created: 4/1/2024

	<u>MATT</u> Inspection Checklist
	1. Is the rail within the MATT curved, between Post 1 and Post 6?

Answer: Yes / No (circle answer)
Correct Checklist Answer: No
Manufacturer Checklist Item: #4
Under NO circumstances shall the rail within the MATT™ be curved, between Post 1 and Post 6.



ON-SITE GUARDRAIL GARDEN TRAINING

	<u>MATT</u> Inspection Checklist
	2. Are all MATT™ post spacings are 6'-3" [1.905 m] on center?

Answer: Yes / No (circle answer)
Correct Checklist Answer: Yes
Manufacturer Checklist Item: #4
Ensure all MATT™ post spacings are 6'-3" [1.905 m] on center. (p 8)



ON-SITE GUARDRAIL GARDEN TRAINING



MATT Inspection Checklist

3. Is the Strut Hole of the MATT™ CR Post 1 Bottom upstream and the Post is 4" above the finished grade?

Answer: Yes / No (circle answer)

Correct Checklist Answer: Yes

Manufacturer Checklist Item: #5

Ensure the Strut Hole of the MATT™ CR Post 1 Bottom with Soil Plate is **upstream** and the Post is 4" [100 mm] (+1", -0") [+25 mm, -0 mm] above the finished grade. (pp 17, 21-22).

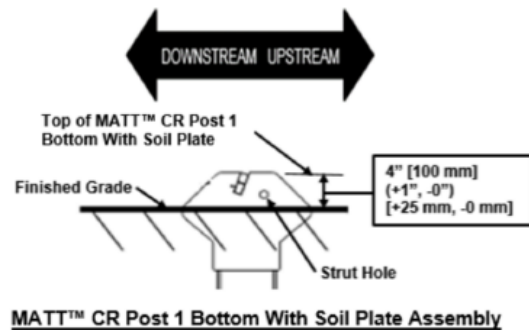

ON-SITE GUARDRAIL GARDEN TRAINING



MATT Inspection Checklist

4. Are the center of the SYTP® yielding holes at Posts 2-5 are approximately centered at finished grade?

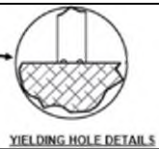

YIELDING HOLE DETAILS

Answer: Yes / No (circle answer)
Correct Checklist Answer: Yes
Manufacturer Checklist Item: #7
Ensure the center of the SYTP® yielding holes at Posts 2-5 are approximately centered at finished grade. (pp 18-20)

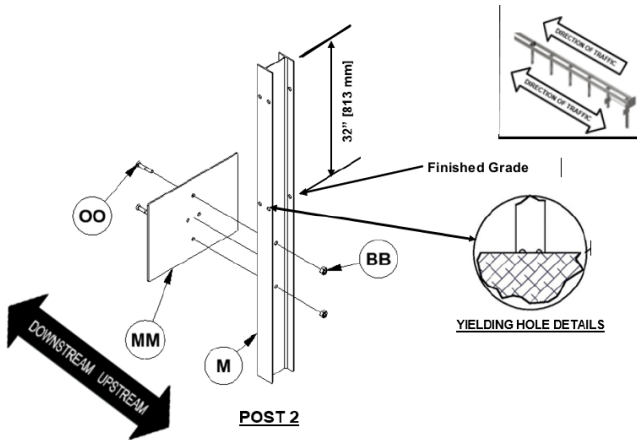

ON-SITE GUARDRAIL GARDEN TRAINING

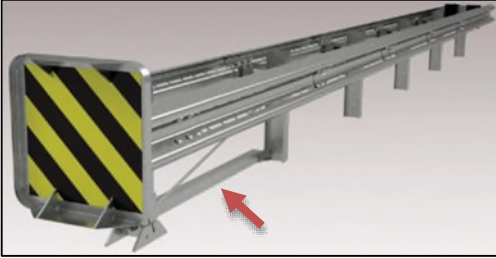
		<u>MATT</u> Inspection Checklist
		5. Are the MATT™ Strut Adapter Plate (at Post 2) and Strut installed between Post 1 and 2 on the post side OPPOSITE the closest traffic?

Answer: Yes / No (circle answer)
Correct Checklist Answer: Yes
Manufacturer Checklist Item: #8
Ensure the MATT™ Strut Adapter Plate (at Post 2) and Strut are installed between Post 1 and 2 on the post side OPPOSITE the closest traffic, when assembled in a Median or Roadside application. When assembled in a Gore application, it is acceptable to place them on either side of the post(s). Ensure the toe of the Strut's vertical leg is pointed down. (p 21)

ON-SITE GUARDRAIL GARDEN TRAINING

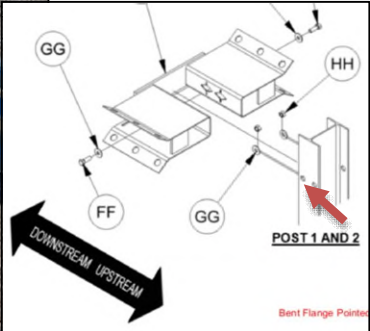
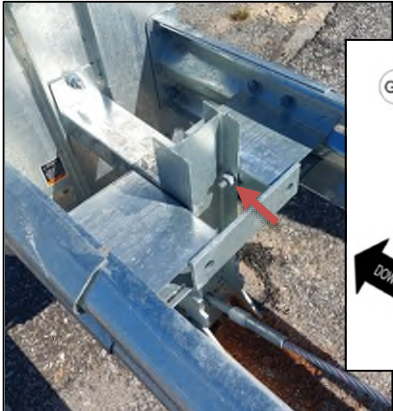

MATT Inspection Checklist

6. Are the downstream slotted holes in the MATT™ Double Spacer bolted to the downstream hole of the MATT CR Post 1 Top and the MATT SYTP® (Post 2)?

Answer: Yes / No (circle answer)
Correct Checklist Answer: Yes
Manufacturer Checklist Item: #9
Ensure the downstream slotted holes in the MATT™ Double Spacer is bolted to the downstream hole of the MATTTMCR Post 1 Top and the MATTTMSYTP®(Post 2). (p 23)

ON-SITE GUARDRAIL GARDEN TRAINING



MATT Inspection Checklist

7. Is the upstream slotted hole in the MATT™ Spacer (Posts 3-5) bolted to the MATT™ SYTP® using the upstream hole in the post?

Answer: Yes / No (circle answer)

Correct Checklist Answer: Yes

Manufacturer Checklist Item: #10

Ensure the **upstream** slotted hole in the MATT™ Spacer (Posts 3-5) is bolted to the MATT™ SYTP® with Soil Plate using the **upstream** hole in the post. (p 24)

ON-SITE GUARDRAIL GARDEN TRAINING



MATT Inspection Checklist

8. Are all MATT™ 12 Gauge Transition Guardrails with Fin-4, at post location 6, lapped in the direction of the nearest adjacent traffic and fins are positioned upstream?

Answer: Yes / No (circle answer)
Correct Checklist Answer: Yes
Manufacturer Checklist Item: #12
Ensure all MATT™ 12 Gauge Transition Guardrails with Fin-4, at post location 6, are lapped in the direction of the nearest adjacent traffic and fins are positioned upstream. (p 25)

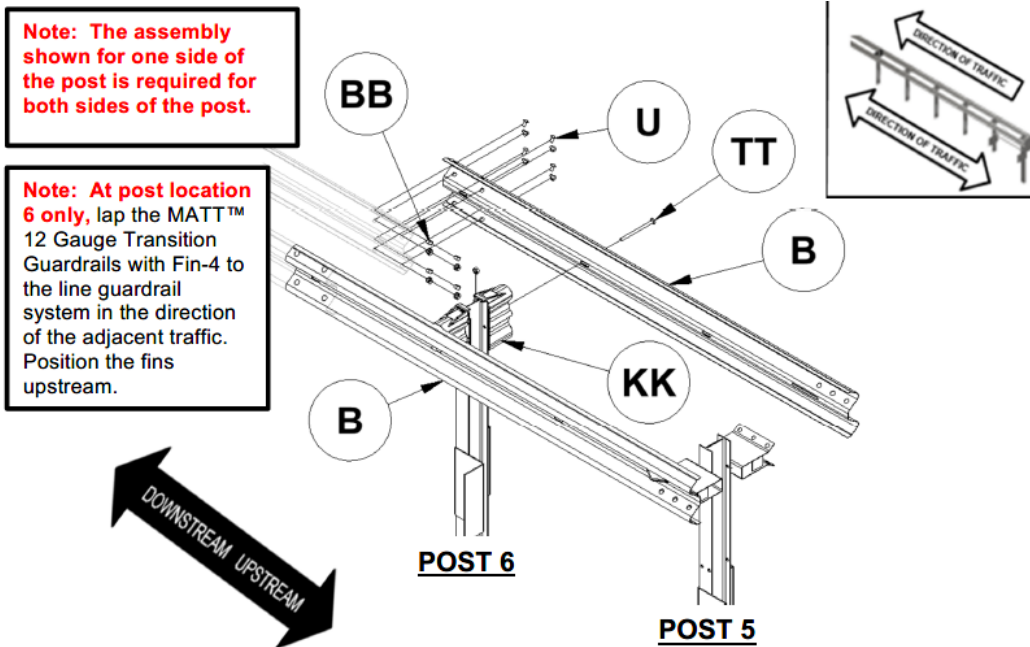

ON-SITE GUARDRAIL GARDEN TRAINING



MATT Inspection Checklist

9. Are the MATT™ 12 Gauge, Slotted Intermediate Guardrails with Fin-3 lapped to the outside of the MATT™ 12 Gauge Transition Guardrails with Fin-4?

Answer: Yes / No (circle answer)

Correct Checklist Answer: Yes

Manufacturer Checklist Item: #13

Ensure the MATT™ 12 Gauge, Slotted Intermediate Guardrails with Fin-3 are **lapped to the outside** of the MATT™ 12 Gauge Transition Guardrails with Fin-4. (p 26)

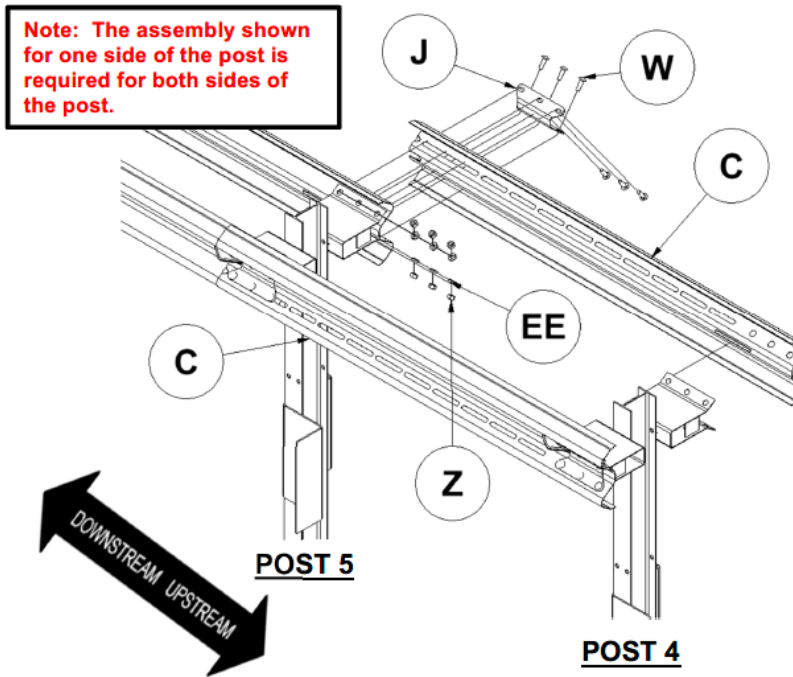

ON-SITE GUARDRAIL GARDEN TRAINING

	<u>MATT</u> Inspection Checklist
	10. Are the MATT™ 12 Gauge, Slotted Intermediate Guardrails with Fin-3 lapped to the outside of the MATT™ 12 Gauge, Slotted Intermediate Guardrails with Fin-3?

Answer: Yes / No (circle answer)
Correct Checklist Answer: Yes
Manufacturer Checklist Item: #14
Ensure the MATT™ 12 Gauge, Slotted Intermediate Guardrails with Fin-3 are lapped to the outside of the MATT™ 12 Gauge, Slotted Intermediate Guardrails with Fin-3. (p 27)



ON-SITE GUARDRAIL GARDEN TRAINING

	MATT Inspection Checklist
	11. Are the MATT™ 12 Gauge, Slotted Intermediate Guardrails-2 lapped to the outside of the MATT™ 12 Gauge, Slotted Intermediate Guardrails with Fin-3?

Answer: Yes / No (circle answer)
Correct Checklist Answer: Yes
Manufacturer Checklist Item: #15
Ensure the MATT™ 12 Gauge, Slotted Intermediate Guardrails-2 are lapped to the outside of the MATT™ 12 Gauge, Slotted Intermediate Guardrails with Fin-3. (p 28)

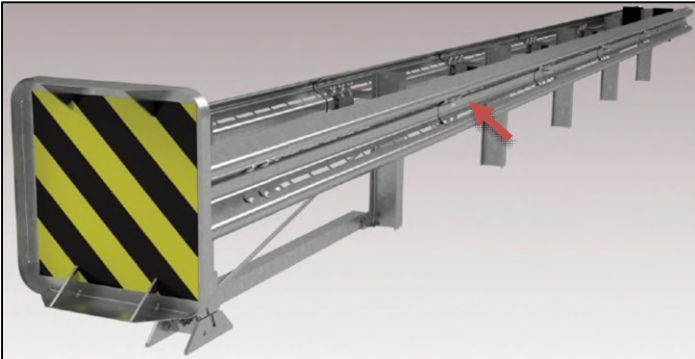

ON-SITE GUARDRAIL GARDEN TRAINING

	<u>MATT</u> Inspection Checklist
	12. Are the MATT™ 10 Gauge, Slotted Front Guardrails-1 lapped to the outside of the MATT™ 12 Gauge, Slotted Intermediate Guardrails-2?

Answer: Yes / No (circle answer)
Correct Checklist Answer: Yes
Manufacturer Checklist Item: #16
Ensure the MATT™ 10 Gauge, Slotted Front Guardrails-1 are lapped to the outside of the MATT™ 12 Gauge, Slotted Intermediate Guardrails-2. (p 29)



ON-SITE GUARDRAIL GARDEN TRAINING



MATT Inspection Checklist

13. Are the MATT™ 10 Gauge Head Rails lapped to the outside of the MATT™ 10 Gauge Slotted Front Guardrails-1?

Answer: Yes / No (circle answer)

Correct Checklist Answer: Yes

Manufacturer Checklist Item: #17

Ensure the MATT™ 10 Gauge Head Rails are **lapped to the outside** of the MATT™ 10 Gauge Slotted Front Guardrails-1. (p 31)

Note: The assembly shown for one side of the post is required for both sides of the post.

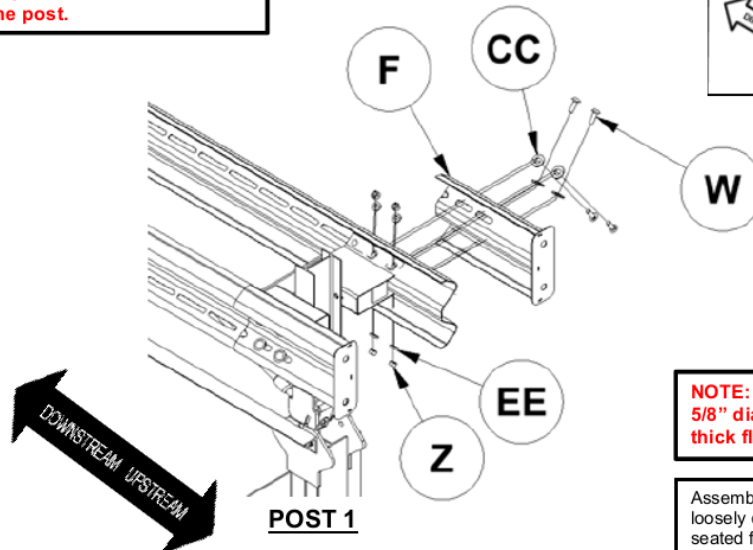

NOTE: Part EE is a 5/8" diameter, 1/4" thick flat washer.

Assemble all hardware loosely ensuring bolt is seated for this step.

Installation tip: Some contractors have found it more efficient to preassemble some portions of Steps 12-14

ON-SITE GUARDRAIL GARDEN TRAINING

	<u>MATT</u> Inspection Checklist
	14. Is the MATT™ Backing Plate assembled on the outside of the MATT™ Guardrail Panels at Posts 2, 3, 4 and 5?

Answer: Yes / No (circle answer)
Correct Checklist Answer: Yes
Manufacturer Checklist Item: #18
Ensure the MATT™ Backing Plate is assembled on the outside of the MATT™ Guardrail Panels at Posts 2, 3, 4 and 5. (pp 26-29)



ON-SITE GUARDRAIL GARDEN TRAINING



MATT Inspection Checklist

15. Are the 5/8" heavy flat washers (1/4" thick) placed between the nut and spacers at Posts 1-5?

Answer: Yes / No (circle answer)

Correct Checklist Answer: Yes

Manufacturer Checklist Item: #19

Ensure the 5/8" heavy flat washers (1/4" thick) are placed between the nut and spacers at Posts 1-5. (pp 26-29)

ON-SITE GUARDRAIL GARDEN TRAINING

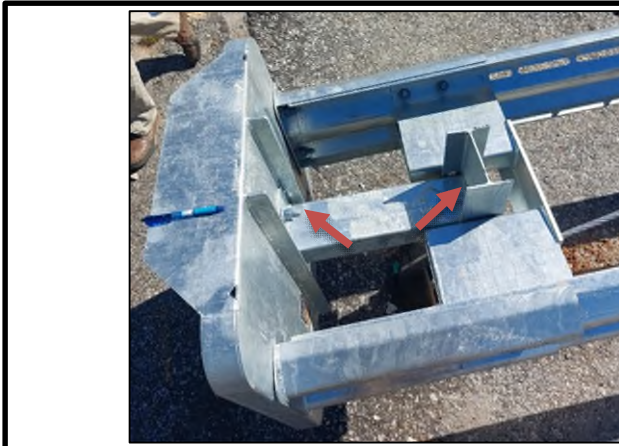

MATT Inspection Checklist

16. Is the MATT™ Head Tube attached to the MATT™ Impact Head and less than 1/4" [6mm] from the MATT™ CR Post 1 Top?

Answer: Yes / No (circle answer)

Correct Checklist Answer: Yes

Manufacturer Checklist Item: #20

Ensure the MATT™ Head Tube is attached to the MATT™ Impact Head and it is less than 1/4" [6mm] from the MATT™ CR Post 1 Top. (pp 33-34)

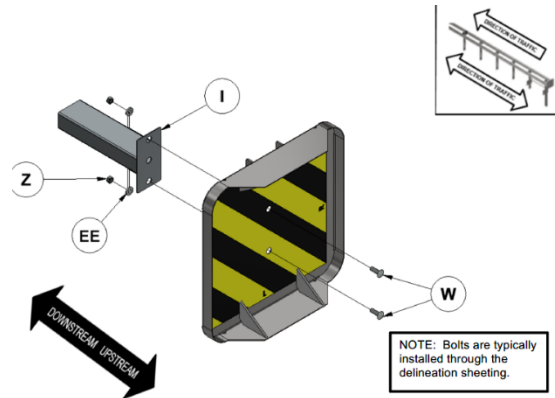

ON-SITE GUARDRAIL GARDEN TRAINING

		<p><u>MATT</u> Inspection Checklist</p> <p>17. Is the Cable Anchor Bracket Angle hooked over the MATT™ CR Post 1 Top and is the cable is taut?</p>
--	---	---

Answer: Yes / No (circle answer)
Correct Checklist Answer: Yes
Manufacturer Checklist Item: #23
Ensure the Cable Anchor Bracket Angle is hooked over the MATT™ CR Post 1 Top and the cable is taut. (pp 30-35)

